

锂离子电池规格书

Specification For Lithium-ion Rechargeable Battery

电芯型号 : N18650CNP

Cell Type : N18650CNP

Document NO.	P/PR03/PB-D-N18650CNP-ZZ-2A	Revised Date	2020-1-11 受控
Version	A/00	Pages	分发号: 13068
Approved	Checked	Designed	
李艳斌	孙新科/宋华杰	吴正杰	

Contents 目录

- 1 Preface前言
- 2 Definition定义
 - 2.1 Standard charge method 标准充电方式
 - 2.2 Standard discharge method 标准放电方式
 - 2.3 Nominal capacity 标称容量
- 3 Cell type and dimension电芯型号及尺寸
 - 3.1 Description and type 电芯说明及型号
 - 3.2 Cell dimension 电芯尺寸
- 4 Battery characteristics电池特性
- 5 Technical requirements技术要求
 - 5.1 Battery usage conditions 电池使用环境
 - 5.2 Battery testing conditions 电池实验环境
 - 5.3 Requirement of the testing equipment 测量仪表要求
 - 5.4 Electrochemical characteristics 电化学特性
 - 5.5 Environmental characteristics 环境适应性能
 - 5.6 Safety characteristics 安全性能
- 6 Package picture包装图片
- 7 Shipment出货
- 8 Warranty质量保证
- 9 Storage and shipment requirement存储及运输要求
- 10 Warning and cautions in handling the lithium-ion battery电池使用时警告事项及注意事项
- 11 The restriction of the use of hazardous substances有害物质控制要求
- 12 Contact information联系方式
- 13 Version history修订履历

Document NO.	P/PR03/PB-D-N18650CNP-ZZ-2A	Version	A/00	Page	1 /13
---------------------	-----------------------------	----------------	------	-------------	-------

1 Preface 前言

This specification describes the type, dimension, performance, technical characteristics, warnings and cautions of the lithium-ion rechargeable battery. The specification only applies to N18650CNP fresh batteries supplied by Zhengzhou BAK Battery Co., Ltd.

本标准描述了圆柱型锂离子电池的型号、尺寸、特性、技术要求及注意事项。本标准仅适用于郑州比克电池有限公司生产的新鲜的圆柱型 N18650CNP 锂离子电池。

2 Definition 定义

2.1 Standard charge method 标准充电方式

At 25 ± 2 °C, the battery is charged to 4.2 V under 0.5 C (1250 mA) constant current, then charged under 4.2 V constant voltage until the current tapers to 0.01 C (25 mA).

在 25 ± 2 °C 下，电池以 0.5 C (1250 mA) 恒流充电至 4.2 V 后，以 4.2 V 恒压充电至电流小于等于 0.01 C (25 mA)。

2.2 Standard discharge method 标准放电方式

At 25 ± 2 °C, the battery is discharged to 2.5 V under 0.2 C (500 mA) constant current.

在 25 ± 2 °C 下，电池以 0.2 C (500 mA) 恒流放电至 2.5 V。

2.3 Nominal capacity 标称容量

The battery nominal capacity, signed as Cap and using mAh as unit, is obtained as per standard charge followed by standard discharge.

电池标称容量以 Cap 表示，单位为毫安时 (mAh)，是指电池按标准充电方式充电后，按标准放电方式放电得到的容量。

3 Cell type and dimension 电芯型号及尺寸

3.1 Description and model 电芯说明及型号

Description: Cylindrical Li-ion rechargeable battery

说明：圆柱型锂离子可再充电电池

Type: N18650CNP

型号：N18650CNP

Document NO.	P/PR03/PB-D-N18650CNP-ZZ-2A	Version	A/00	Page	2 /13
---------------------	-----------------------------	----------------	------	-------------	-------

3.2 Cell dimension 电芯尺寸

Cell physical dimension listed in Figure 1(unit: mm).

电芯尺寸示意图如图 1 所示（单位：mm）。

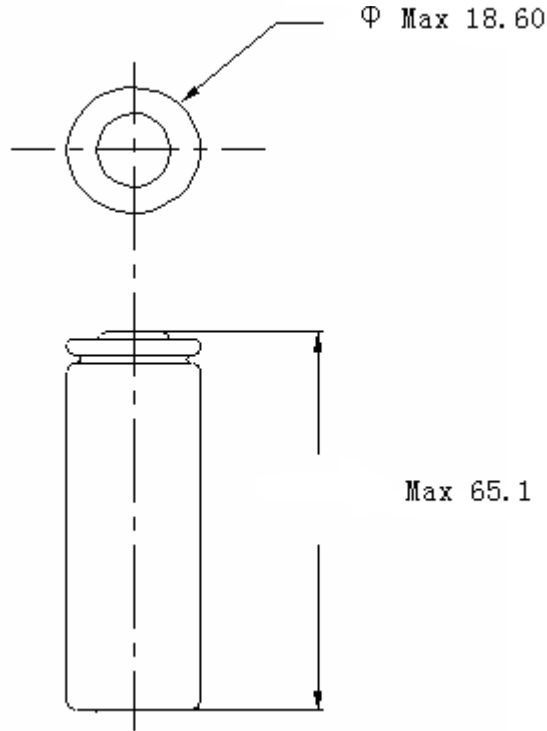

Figure 1/ 图 1

4 Battery characteristics 电池特性

Unless otherwise specified, the battery is fresh battery and tested by standard charge and standard discharge.

除非有特殊说明，否则所有样品均为新鲜电池，且按标准充电和标准放电方式进行测试。

ITEM 项目	SPECIFICATION 规格
Nominal capacity 标称容量	2500 mA h @ 0.2C By standard charge / discharge
Minimum capacity 最低容量	2400 mA h @ 0.2C By standard charge / discharge
Nominal voltage 标称电压	3.6V
Charge voltage 充电电压	4.2V
Discharge cut-off voltage 放电终止电压	2.5V

Document NO.	P/PR03/PB-D-N18650CNP-ZZ-2A	Version	A/00	Page	3 /13
---------------------	-----------------------------	----------------	------	-------------	-------

Rated charge current 倍率充电电流	4A (25℃)
Max continuous discharge current 最大持续放电电流	20A (25℃)
Operating Temperature (Cell surface) 工作温度 (电池表面温度) ①	0~50℃ (Charge 充电), 特殊要求时, 再次充电, 温度须<45℃ -20℃~75℃ (Discharge 放电), 特殊要求时, 再次放, 电温度须<50℃
Humidity range 湿度范围	0 ~ 60 % RH (non-condensing 不冷凝)
Internal resistance 内阻	≤ 16 mΩ (AC Impedance, 1000 Hz)
Battery dimension 电池尺寸	Height: 65.10 mm Max 最大高度: 65.10 mm Diameter: 18.6 0mm Max 最大直径: 18.60mm
Weight 重量	≤ 48g

①: 上述所规定的温度即为电池包工作过程中最高(低)处的温度;

5 Technical requirements 技术要求

5.1 Battery usage conditions 电池使用环境

Charge temperature (Cell surface temperature) 充电温度: 0 ~ 50 °C

Discharge temperature (Cell surface temperature) 放电温度: -20 ~ 75 °C

5.2 Battery testing conditions 电池试验环境

Unless otherwise specified, all tests stated should be done at 25± 2 °C.

除非有特殊说明, 所有测试须在 25± 2°C下完成。

5.3 Requirement of the testing equipment 测量仪表要求

The voltage measurement device: not less than 0.5 grade

电压测量装置: 不低于 0.5 级

The current measurement device: not less than 0.5 grade

电流测量装置: 不低于 0.5 级

AC Impedance: 1000 Hz

交流阻抗测量频率: 1000 Hz

Temperature meter: precision ≤ 0.5 °C

温度仪表要求: 精度为≤0.5 °C

Time measurement tolerance: ± 0.1 %

时间测量公差: ± 0.1 %

The size measurement tolerance: ± 0.1 %

This spec manual is the enterprise standard of Zhengzhou BAK Battery Co., Ltd. Without authorization, any pirate or circulation is prohibited.

本规格书为郑州比克电池有限公司企业标准, 未经授权, 禁止翻印、传播。

Document NO.	P/PR03/PB-D-N18650CNP-ZZ-2A	Version	A/00	Page	4 /13
---------------------	-----------------------------	----------------	------	-------------	-------

尺寸测量公差: $\pm 0.1\%$

The quality measurement tolerance: $\pm 0.1\%$

质量测量公差: $\pm 0.1\%$

5.4 Electrochemical Characteristics 电化学性能

Unless otherwise specified, the battery should be fresh battery and tested by standard charge and standard discharge.

除非有特殊说明, 否则所有样品均为新鲜电池, 且按标准充电和标准放电方式进行测试。

No. 序号	Item 测试项目	Test method and conditions 测试方法与条件	Criterion 性能标准
5.4.1	Rate discharge capability 倍率放电性能	Standard charge followed by constant current discharge to 2.5 V at specified discharge rates at $25\pm 2^\circ\text{C}$. 按标准充电方式充电后, 在 $25\pm 2^\circ\text{C}$ 下以给定放电倍率恒流放电至 2.5 V。	$\frac{\text{discharge capacity at } 2.5\text{A}}{\text{discharge capacity at } 0.5\text{A}} \geq 95\%$ $\frac{2.5\text{A放电容量}}{0.5\text{A放电容量}} \geq 95\%$ $\frac{\text{discharge capacity at } 20\text{A}}{\text{discharge capacity at } 0.5\text{A}} \geq 90\%$ $\frac{20\text{A放电容量}}{0.5\text{A放电容量}} \geq 90\%$
5.4.2	RT cycle life 常温循环寿命	Charge: 2A constant current charge to 4.2 V followed by 4.2 V constant voltage charge to cut-off current : 0.04 C (0.1A), rest for 10min; Discharge: 20 A constant current discharge to cut-off voltage : 2.5 V (T-cut 75°C , re-discharge at 50°C), rest for 45min. 充电: 以 2A 恒流充电至 4.2 V 后, 以 4.2 V 恒压充电至电流 0.04C (0.1A), 静置 10min; 放电: 以 20 A 恒流放电至截止电压 2.5 V (温度大于 75°C 停止放电, 低于 50°C 继续放电), 静置 45min。	Capacity $\geq 1500\text{mAh}$ @ after 300 cycles (60% of the stander capacity@RT) 循环 300 圈之后电芯容量 $\geq 1500\text{mAh}$ (25°C 标准制式下容量的 60%)

Document NO.	P/PR03/PB-D-N18650CNP-ZZ-2A	Version	A/00	Page	5 /13
---------------------	-----------------------------	----------------	------	-------------	-------

5.4.3	High-low temperature discharge performance 高低温放电性能	Standard charge followed by 2.5 A constant current discharge to 2.5 V at specified temperature. Discharge cut-off voltage shall be 2.0 V when discharge temperature is below -10 °C. 按标准充电方式充电后，在指定温度下以 2.5 A 电流恒流放电至截止电压 2.5 V。当放电温度低于-10 °C时，放电截止电压为 2.0 V。	$\frac{\text{discharge capacity at } -20\text{ }^{\circ}\text{C}}{\text{discharge capacity at } 25\text{ }^{\circ}\text{C}} \geq 70\%$ $\frac{-20\text{ }^{\circ}\text{C 放电容量}}{25\text{ }^{\circ}\text{C 放电容量}} \geq 70\%$ $\frac{\text{discharge capacity at } 60\text{ }^{\circ}\text{C}}{\text{discharge capacity at } 25\text{ }^{\circ}\text{C}} \geq 100\%$ $\frac{60\text{ }^{\circ}\text{C 放电容量}}{25\text{ }^{\circ}\text{C 放电容量}} \geq 100\%$
5.4.4	Storage performance at 25 °C/60 °C (100% SOC) 25 °C满电存储性能	(1) Standard charge 标准充电方式充电 (2) Stored at 25 °C for 30days 于 25 °C/60°C下存储 30 天 (3) Standard discharge 标准放电方式放电	$\frac{\text{存储30天恢复容量}}{\text{初始容量}} \geq 90\%$

Document NO.	P/PR03/PB-D-N18650CNP-ZZ-2A	Version	A/00	Page	6 /13
---------------------	-----------------------------	----------------	------	-------------	-------

5.5 Environmental characteristics 环境适应性能

(The following test according to UL1642 以下测试方法来自 UL1642)

NO. 序号	ITEM 测试项目	CRITERION 性能标准	TESTING METHOD 测试条件与方法
5.5.1	Vibration 振动性能	There shall be no electrolyte leakage 电解液无泄漏	After standard fully charge, cell shall be attached to a vibration table directly and subjected to vibration that consists of 10 Hz to 55 Hz to 10 Hz at the speed of 1Hz/min in 90~100mins. The total excursion of the vibration is 0.8mm(0.060 inches). The cell shall be vibrated in each direction along axis of the cylinder and the vertical directions of axis of the cylinder. 将满电电芯放在振动实验台上, 在 90~100mins 由 10 Hz 到 55 Hz 再到 10Hz 以 1Hz/min 的速率变化, 振幅为 0.8mm(0.060 英寸)进行振动实验。电芯在电芯的轴向和与电芯轴向垂直的两个方向上振动。

5.6 Safety characteristics 安全性能

NO. 序号	ITEM 测试项目	CRITERION 性能标准	TESTING METHOD 测试条件与方法
5.6.1	overcharge test 过充测试	No leakage、No flame、No fire、No explode 电芯不漏液、不冒烟、不起火、不爆炸	The cell is discharged following the standard discharge method. Apply a 12V power supply and a 1C charge current for 1.5hrs. 电芯按照标准放电方式放完电后, 采用 1C 电流 12V 电压恒流恒压充电 1.5 小时。
5.6.2	Over discharge test 过放测试	No leakage、No flame、No fire、No explode 电芯不漏液、不冒烟、不起火、不爆炸	Cell shall first be charged according to standard charge method, and then cell is to be discharged by 0.2C current for 12 hours; The test is completed when the cell is to be discharged up to 250% of rate capacity or the other protective devices prevent the discharge. 电芯按照标准充电方式充满电后, 以 0.2C 放电 12 小时直到放电容量达到额定容量的 250%或者保护装置动作为止。

Document NO.	P/PR03/PB-D-N18650CNP-ZZ-2A	Version	A/00	Page	7 /13
---------------------	-----------------------------	----------------	------	-------------	-------

5.6.3	130°C hot oven test 130°C热箱测试	When the temperature of the cell is 130°C. Cell must not fire or explode in 60 minutes 电芯表面温度达到 130°C后的 60 分钟内, 电芯不起火、不爆炸	<p>The cell is charged following the standard charge method. After charging the cell is put in the oven. And then the oven temperature will be ramped at 5°C per minute to 130°C and held at 130°C. When the temperature of the cell reach 130°C, the cell is maintained in the 130°C oven for a maximum of 60 minute or until a fire or explosion is obtained, whichever comes first. Record the time that the cell temperature reaches 130°C and the time when a fire or explosion occurs.</p> <p>电芯按照标准充电方式充满电后, 将电芯放进热箱里, 然后将热箱按 5°C/min 升温到 130°C, 当电芯的温度也达到 130°C时, 电芯在热箱 130°C环境下保持 60 分钟或者电芯起火爆炸为止。记录电芯温度升至 130°C起直到电芯起火或爆炸的时间。</p>
5.6.4	Crush test 挤压测试	No fire、No explode 电芯不起火、不爆炸	<p>After charging a cell following the standard charge method, the cell shall be crushed between two flat surfaces. The direction of the crushing force shall be vertical to axis of the cylinder. The crushing force is to be applied by a hydraulic ram with a 32mm diameter piston. Crushing force is approximately 13 KN. Once the maximum pressure has been obtained it is to be released.</p> <p>电芯按照标准充电方式充满电后, 放在两个平整的表面进行挤压测试, 压力器必须施加一个与圆柱电芯轴向垂直的力, 平压于电芯。采用 32 mm 直径的液压活塞, 所用压力为 13 KN, 一旦达到最大压力值, 即释放压力。</p>
5.6.5	Impact test 重物冲击测试	No flame、No fire、No explode 电芯不冒烟、不起火、不爆炸	<p>Cell shall first be charged according to standard charge method, then the battery cell was placed on a flat surface so that the longitudinal axis of the battery cell shall be parallel with it.</p> <p>A 15.8±0.2 mm diameter bar is to be placed across the center of the sample. A 9.1±0.1 kg weight is to be dropped from a height of 610±25 mm on the sample.</p> <p>电芯按照标准充电方式充满电后, 水平放置于一个与电芯纵轴平行的平板。将一直径 Φ15.8±0.2 mm 的棒放在样品中心, 让重量 9.1±0.1 kg 的重物从 610±25 mm 的高度落到实验电芯上</p>

Document NO.	P/PR03/PB-D-N18650CNP-ZZ-2A	Version	A/00	Page	8 /13
---------------------	-----------------------------	----------------	------	-------------	-------

5.6.6	Short circuit test 短路测试	No fire、No explode 电芯不起火、不爆炸	<p>Cell shall first be charged according to standard charge method, and then cell is to be short-circuited by connecting the positive and negative terminals of the cell with copper wire having a maximum resistance load of $80 \pm 20\text{m}\Omega$.</p> <p>This test is done at room temperature and at 60°C (different cells). Monitor the cell temperature while testing. The cell is continuously discharged until the cell case temperature has returned to be 10°C less than peak temperature.</p> <p>电芯按照标准充电方式充满电后, 在室温和 60°C 进行短路实验, 将接有热电偶的电芯置于通风橱中, 用铜线短路其正负极(线路总电阻 $80 \pm 20\text{m}\Omega$), 实验过程中监视电芯温度变化, 当电芯温度下降到比峰值低 10°C 时, 结束实验。</p>
5.6.8	Incineration test 焚烧测试	<p>When subjected to the test no part of exploding cell shall penetrate from the screen such that some or all the cell or battery protrudes through the screen</p> <p>爆炸的电芯没有任何一个部分通过或者透过金属网筛</p>	<p>After full charging by the standard method, each test sample cell or battery is to be placed on a platform table having a 4-inch diameter hole in the center covered by a screen. The screen over the hole is to be steel wire mesh having 20 openings per inch and a wire diameter of 0.017 inch An eight-sided covered wire cage, 2 feet across and 1 foot high is covered with a metal screen is to be constructed from 0.010inch diameter wire with 16-18 wires per inch in each direction. This wire cage is placed over to the test sample. The sample is to be placed on the screen covering the hole in the center of the hole. It is to be heated until it explodes, or until it is destroyed.</p> <p>电芯以 0.5C 充满电后, 每次试验的样品电芯放置于一个平台桌子上, 桌子中间有一个直径为 102mm (4 英寸) 被网筛覆盖的洞, 网筛由每英寸 (25.4mm) 20 孔、钢丝直径为 0.42mm (0.017 英寸) 的钢丝网组成。在试验样品电芯上要罩上由铝做成的丝网, 丝网共八面, 每面 610mm (2 英尺) 宽、305mm (1 英尺) 高, 金属网由直径 0.25mm (0.010 英寸) 的铝丝编织成, 在每个方向上, 每英寸 (25.4mm) 有 16~18 根铝丝组成。样品放在覆盖桌子中间洞的网筛上加热直至起火爆炸或者完全破坏。</p>
Note 备注	<p>All above safety tests will be conducted at $25^\circ\text{C} \pm 2^\circ\text{C}$ except where specified differently. Use proper ventilation with protective equipment.</p> <p>除特殊说明, 以上所有安全测试均应在 $25^\circ\text{C} \pm 2^\circ\text{C}$ 通风橱中, 且附带有保护装置的情况下进行。</p>		

Document NO.	P/PR03/PB-D-N18650CNP-ZZ-2A	Version	A/00	Page	9 /13
---------------------	-----------------------------	----------------	------	-------------	-------

6 Package picture 包装图片



Small box

big box

pallet

(100pcs batteries in a small box, 2 small boxes in a big box)

7 Shipment 出货

The battery shall be shipped in voltage range of 3.5 ~ 3.8 V or in accordance with customers' requirement. The remaining capacity before charging shall be changed depending on the storage time and conditions.

单体电池按 3.5 ~ 3.8 V 的充电电压或客户要求出货，电池出货后充电前的剩余容量取决于储存时间和条件。

8 Warranty 质量保证

The battery warranty period is made according to business contract. BAK will replace no batteries for free after shipment if there are problems due to customers' abuse or misuse instead of BAK's manufacturing failure.

电池的保质期限依合同而定，交货之后，如非郑州比克电池有限公司的制程原因，而是客户的滥用和误用造成的电池质量问题，郑州比克电池有限公司不承诺免费更换。

BAK will not be responsible for the trouble caused by handling in violation of cautions in instructions.

郑州比克电池有限公司对违反安全守则操作所产生的问题不承担任何责任。

BAK will not be responsible for the trouble caused by matching electric circuit, battery pack and charger.

郑州比克电池有限公司对与电路、电池组和充电器搭配使用所产生的问题不承担任何责任。

BAK will not be responsible for any defect of batteries caused during assembling after acceptance.

出货后客户在电池组装过程中产生的不良电池不在郑州比克电池有限公司质量保证的范围之列。

Document NO.	P/PR03/PB-D-N18650CNP-ZZ-2A	Version	A/00	Page	10 /13
---------------------	-----------------------------	----------------	------	-------------	--------

9 Storage and shipment requirement 存储及运输要求

Item 项目	Conditions 环境	Permissible time 允许时间
Storage environment 储存环境	45 °C ~ 60 °C, 60% RH Max	Less than 1 month 少于 1 个月
	25 °C ~ 45 °C, 60% RH Max	Less than 3 months 少于 3 个月
	-20 °C ~ 25 °C, 60% RH Max	Less than 1 year 少于 1 年
About long time storage: If the battery needs to be stored for a long time, the battery's storage voltage should be 3.5 ~ 3.8 V. Also, it is recommended to charge the battery every six months. 关于长期存储: 若电池需长期存储, 电池的存储电压应该为 3.5 ~ 3.8 V。同时, 建议每 6 个月对电池进行充电。		

10 Warning and cautions in handling the lithium-ion battery 电池使用时警告事项及注意事项

Battery abuse can cause damage to the battery and/or personal injury. Please read and observe the standard battery precautions below before utilization.

电池滥用可能会造成对电池的损害或对人身伤害, 在使用前, 请仔细阅读以下安全守则。

Note 1, the customer is required to contact Zhengzhou BAK Battery Co., Ltd. in advance, if and when the customer needs other applications or operating conditions not described in this specification.

注释 1, 客户如需在本规格书所述之外的条件下使用电池, 请提前联系郑州比克电池有限公司。

Note 2, Zhengzhou BAK Battery Co., Ltd. will take no responsibility for any accident when the battery is used under other conditions not described in this specification.

注释 2, 如在本规格书所述条件之外使用电池而发生事故, 郑州比克电池有限公司不承担任何责任。

Warnings 警告

To prevent damage or injury from battery leaking, heating and/or explosion, please observe the following precautions before use. (It should be indicated especially in manual or instruction for users.)

为避免因电池泄漏、发热和/或爆炸造成伤害, 请在使用前注意以下预防措施。(应在使用说明手册或说明书中特别注明)

Document NO.	P/PR03/PB-D-N18650CNP-ZZ-2A	Version	A/00	Page	11 /13
1	Do not use and leave the battery near a heat source such as fire or heater. 禁止在火、加热器待高温热源附近使用和留置电池。				
2	Do not use or leave the battery at very high temperature conditions (e.g., strong direct sunlight or a vehicle in extremely hot conditions). Otherwise, it can overheat or catch fire or its performance will be degenerate and its service life will be decreased. 禁止在高温下（直热的阳光下或很热的汽车中）使用或留置电池，否则可能会引起电池过热、起火、功能失效和寿命减短。				
3	Do not short circuit, over-charge or over-discharge the battery. 不要将电池短路、过充或过放。				
4	Don't immerse the battery in water and seawater. Please put it in cool and dry environment if no using. 严禁将电池浸入海水或水中，保存不用时，应放置在阴凉干燥的环境中。				
5	Don't reverse the positive and negative terminals 严禁颠倒正负极使用电池。				
6	Do not disassemble or modify the battery. 不要拆卸或修整电池。				
7	Do not transport or store the battery together with metal objects such as necklaces, hairpins, coins, etc. 禁止将电池与金属，如发夹、项链等一起运输或贮存。				
8	Make sure the battery is not with conspicuous damage or deformation. 不要使电池受到明显的损害或变形。				
9	Don't connect the battery to an electrical outlet directly. 严禁将电池直接插入电源插座。				
10	If the battery leaks and the electrolyte splashes into the eyes, rinse the eyes with clean running water immediately for at least 15 minutes, and go to hospital for treatment if necessary. 如果电池发生泄露，电解液进入眼睛，请立即用流动的清水冲洗眼睛至少 15 min，必要时请立即前往医院接受治疗。				
11	Mixed use of batteries of different types is not allowed. 禁止与液态锂离子或不同型号的锂电池混合使用。				
12	Keep the battery away from babies. 避免让小孩接触电池。				
13	Do not directly solder the battery and pierce the battery with a nail or other sharp objects. 禁止直接焊接电池和用钉子或其它利器刺穿电池。				
14	Do not strike, throw or trample the battery. 禁止敲击、抛掷或踩踏电池等。				
15	Use the battery charger specifically for that purpose when charging. 请选用锂离子电池专用充电器进行充电。				
16	Please separate battery of different electrochemical systems from one another when disposing of secondary battery. 二次电池处理时，请将电池和其他电化学体系的产品分开。				
17	Clean the terminals with a dry cloth before use if the battery terminals are dirty. Otherwise power failure or charge failure may occur due to the poor connection with the instrument. 如果电池弄脏，使用前应用干布抹净，否则可能会导致接触不良功能失效。				

Document NO.	P/PR03/PB-D-N18650CNP-ZZ-2A	Version	A/00	Page	12 /13
--------------	-----------------------------	---------	------	------	--------

18	Batteries should be removed from the device or charger immediately and not used again if they are over heat, give off odor, discolor or deform, or appear abnormally in any way during use, charging and storage.
	如果电池发出异味、发热、变色、变形，或在使用、贮存和充电过程中出现任何异常现象，立即将电池从装置或充电器中移离并停用。
19	The battery replacement shall be done only by either battery supplier or device supplier instead of the user.
	更换电池应由电池供应商或设备供应商完成，用户不得自行更换。
20	Please tape the terminals to insulate batteries before discarding them in case of fire and explosion.
	废弃电池之前应用绝缘纸包住电极，以防起火、爆炸。
21	Do not use battery in strong electrostatic and magnetic occasions, otherwise, it can cause safety problems easily.
	禁止在强静电和强磁场的地方使用，否则易带来不安全的隐患。
22	Use of damaged battery is not permitted.
	禁止使用已损坏的电池。
23	Make sure package designing will not cause battery damages.
	电池外壳设计和包装禁止损伤电池。
24	Battery packing should be conducted strictly according to level range, any misuse of different levels should not be permitted.
	电池配组时需严格按等级执行，不能跨等级成组。
25	Disassembling battery from pack or module is not permitted unless under the guidance of professional technicians.
	严禁将电池从电池包或电池模组中拆卸，除非在专业技术人员的指导下进行。

11 The restriction of the use of hazardous substances 有害物质控制要求

This model of lithium-ion battery is in accordance with our company's request of "The hazardous substances and material management standard" or customer's requirements.

本型号锂离子电池符合本公司《有害物质与材料管理规范》要求或参照客户要求执行。

12 Contact information 联系方式

If you have any questions regarding the battery, please contact the following address:

如有疑问，请按以下地址联系：

Headquarter: Liuqiao Village Zhengnan town Zhongmou country Zhengzhou Henan China (451470)

厂址：河南省郑州市中牟县郑庵镇刘巧村委 (451470)

Tel: +86-0371-62033103 (Engineer Wang)

电话：+86-0371-62033103 (王工)

Document NO.	P/PR03/PB-D-N18650CNP-ZZ-2A	Version	A/00	Page	13 /13
---------------------	-----------------------------	----------------	------	-------------	--------

13 Version change record 修订履历

Version 版次	Change Content 修改内容	Page 页码	PIC 修改人	Date 修改日期
A/00	无	ALL	吴正杰	2020-1-11