

# MACH3 USB interface board instruction

BL-UsbMach-V2.1

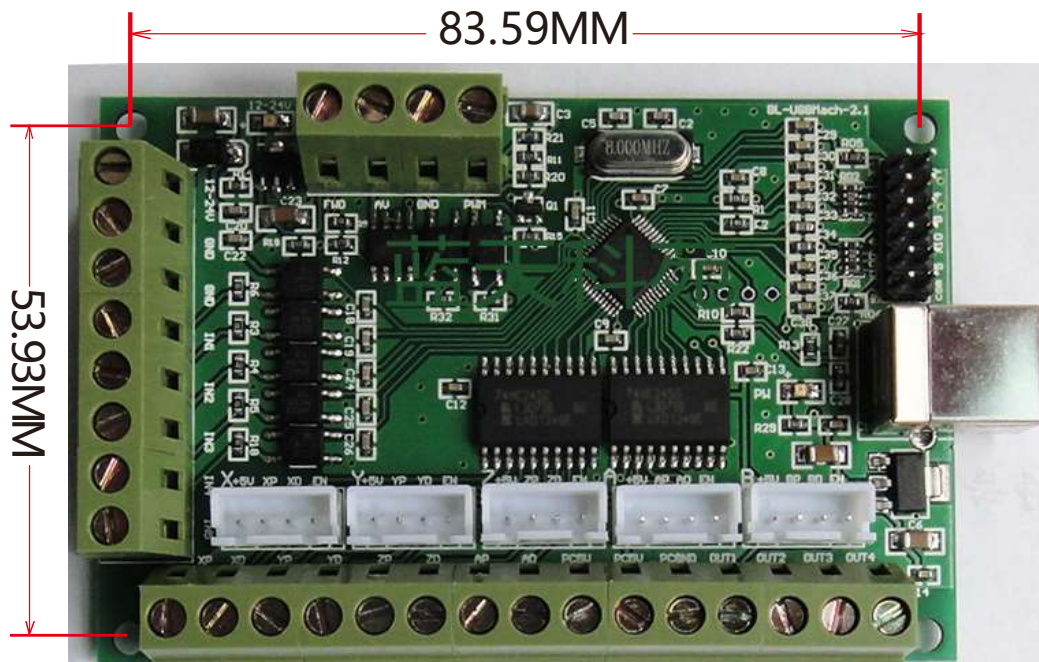

## Functions and Features:

- 1、 Completely support MACH3 software.
- 2、 Support windows XP、WIN7、WIN8、WIN10, support 32 bit and 64 bit system, and tablet PC.
- 3、 Wide range external power supply voltage , 12 - 24V, and has preventing reverse connection function.
- 4、 All the input signals are separated by photocouplers, can be connected to Estop、 Probe and Limit switches. To make your computer safe.
- 5、 0-10V analog voltage output(photocoupler separated), can be connected to Frequency converter, using to control the spindle speed.
- 6、 PWM output is available(photocoupler separated, 5V), can be used to control the spindle speed controller that controlled by PWM.
- 7、 Four output ports are available, can be connected to relay modules with photocouplers, to control flood and mist etc.

Mach3 USB interface board BL-UsbMACH-V2.1 manual

- 8、 Can be connected to stepper motor drivers using common anode or common cathode input connection. Note: stepper motor drivers should have photocouplers for input.
- 9、 Also provide 5 axis XH2.54-4P 2.54mm Socket Connector, make it is easy to connect to the stepper motor drivers.
- 10、 All the port names are printed on board, Easy to be used.

Function Wiring diagram:

BL-USBMach3 5 Axis Interface Board

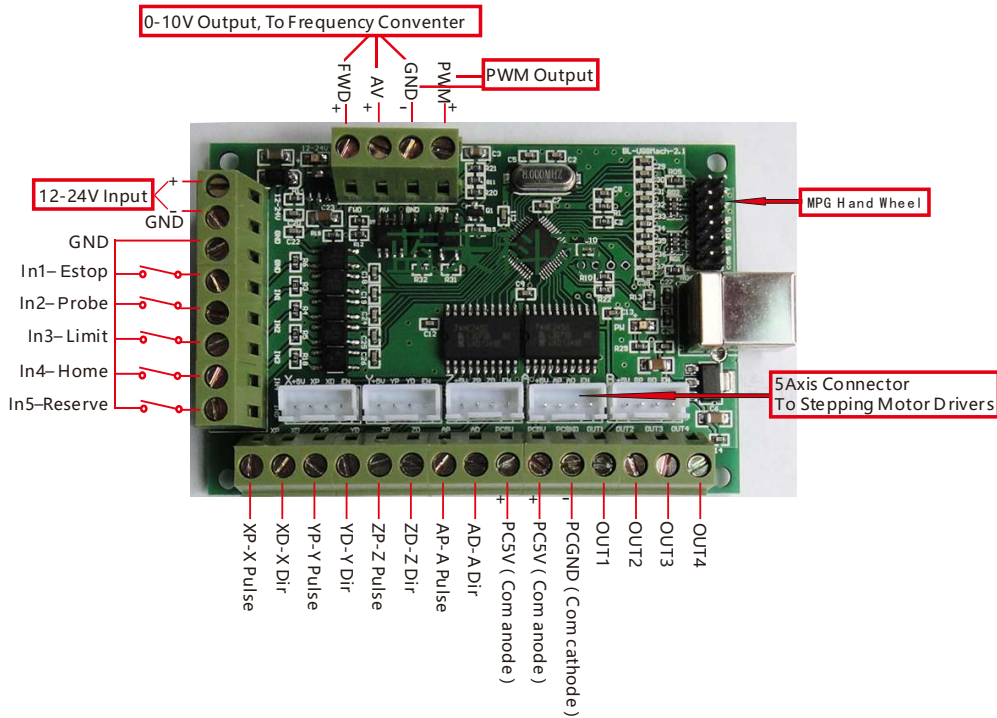

Wiring Sample For X Axis Com Anode

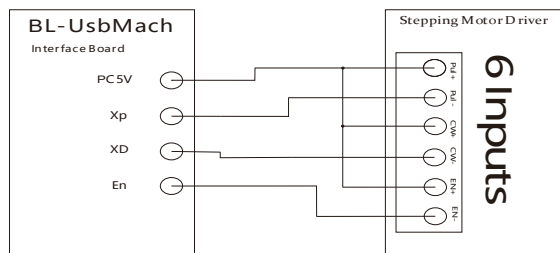

**Note:** *En* can be disconnected, It's alternative. So, there is no EN on screw-type terminal .

## Mach3 USB interface board BL-UsbMACH-V2.1 manual

**Notice:** The settings bellow are base on that the interfaceboard and the stepper motor drivers are connected with common anode.

### Settings for MACH3:

#### A、 Install MACH3 software and driver :

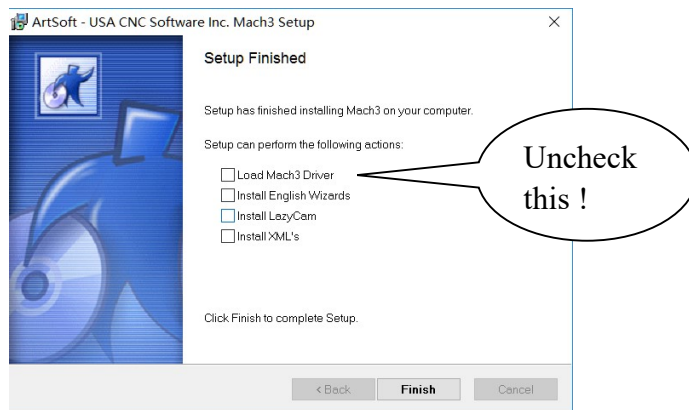

(1) Install MACH3 software: like the figure above, Normally install MACH3, untill the figure above appeared, don't check the first checkbox (LoadMach3Driver), and the other 3 checkboxes can be not checked too, click Finish done.

(2)、 copy all the files in folder “BL-USBMach3 driver and settings” , To MACH3 install folder, and replace the old files.

After coping the setting files, the settings for MACH3 are done basically. And no need to set mach3 software again that the way is shown bellow.

(3)、 Set the compatibility:

Use the mouse right click Mach3Mill icon, then click property:



## Mach3 USB interface board BL-UsbMACH-V2.1 manual



### B、 Run the software:

**Plug USB cable to the interfaceboard, and run MACH3 software, when this appear:**

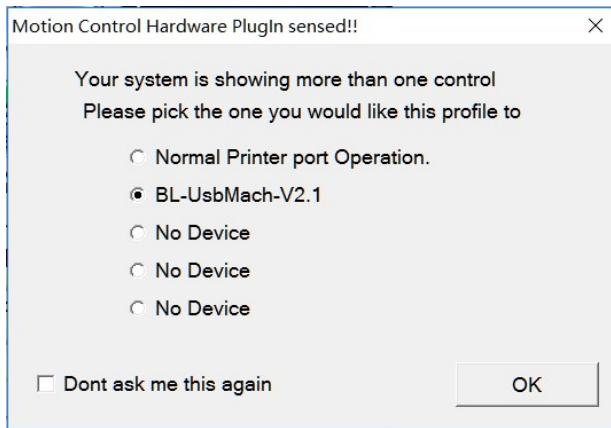

**Check UsbMach-V2.1.**

### C、 Setting the Speed:

On MACH3 drop down menu, click PluginCtrl>BL-USBMach, and this interface will appear:

## Mach3 USB interface board BL-UsbMACH-V2.1 manual

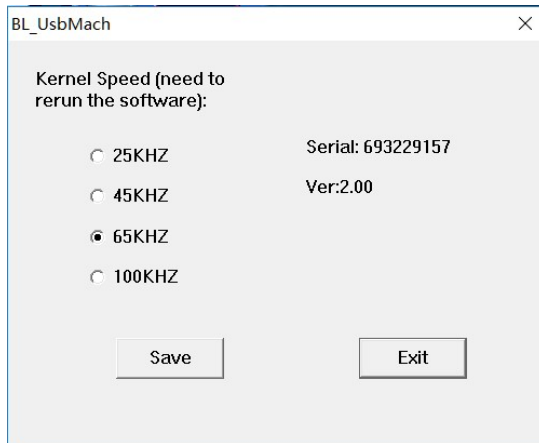

You need to restart the Mach3 software to make the new speed active.  
If you don't change the speed, normally it's 65KHZ.

### D、Configuring Mach3:

1、Use Config>Setup Units to choose MM's (see the figure bellow).

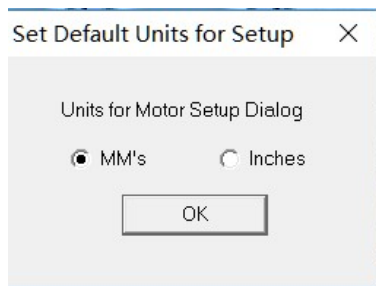

### 2、Ports/Pins

Notice—**After change the settings, you need to click the save button !**

(a) Motor Outputs: Configure like the figuer bellow。

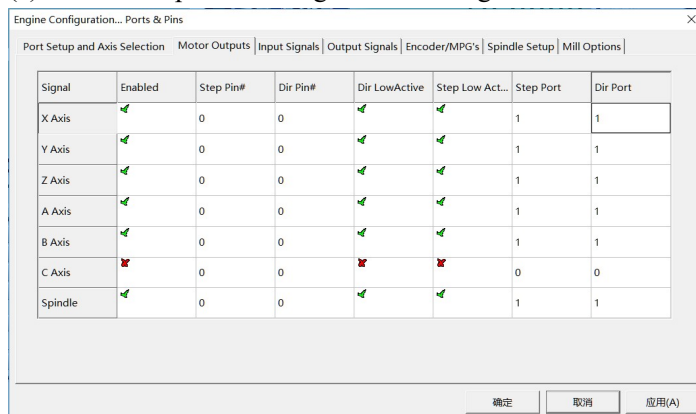

Here you no need to fill the StepPin and DirPin。

DirLowActive—Use to change the turning direction of the stepper motor。

StepLowActive---check it when connect **stepper motor drivers using common anode; and don't check when using common cathode.**

Mach3 USB interface board BL-UsbMACH-V2.1 manual

Note: the turning direction of the stepper motor is relate to the wiring way that the stepper motor and the driver is connected with, if the direction is not right, you can also change the wiring way (just change A、 B phase)。

It is suggested to use **common anode to connect the stepper motor driver.**

(b)、InputSignals: Configure like the figuer bellow。

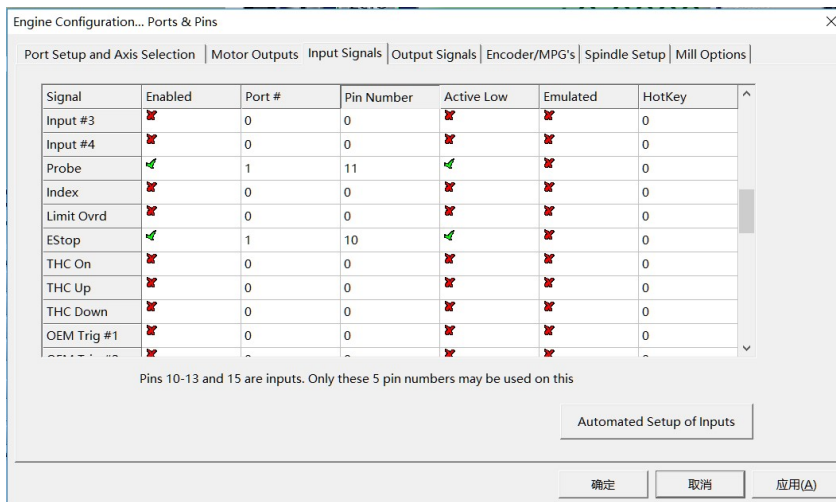
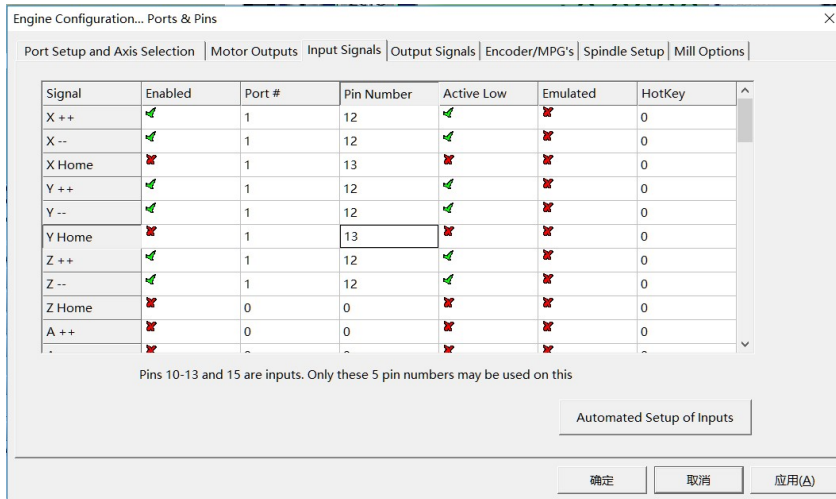

Here 10、 11、 12、 13、 15 respectively represent In1、 In2、 In3、 In4、 In5 on the interface board。 You can use any input for the the same input signal. For example, for X++, if you fill 12, that means you use IN3, if you fill 13, that means you use IN4 for X++.

**Mach3 USB interface board BL-UsbMACH-V2.1 manual**

(c)、Output signals: Configure like the figuer bellow。

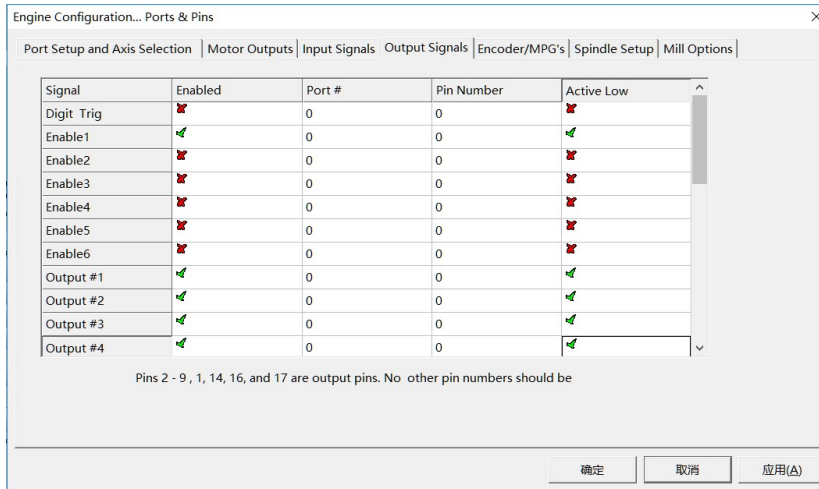

Enable1: enable the stepper motor driver. If you check it , When the “Reset” button flash, it will disable the stepper motor driver. If you don’t need this function ,then don’t check it.  
 Output #1、Output #2、Output #3、Output #4 are 4 Outputs。 If configure like the figure above, when it act ,it’s voltage will be low, or it will be high。 If wou check the ‘ActiveLow’, they will behave opposite。

(5)、Spindle Steup: Configure like the figuer bellow。

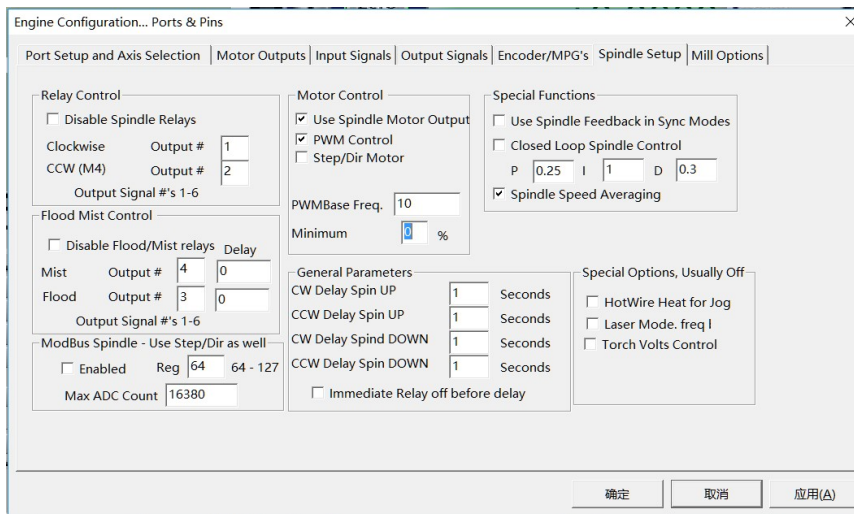

You can use PWM or 0-10V to control the spindle speed, But also need to set “spindle pulley”, click config>spindlepulleys:

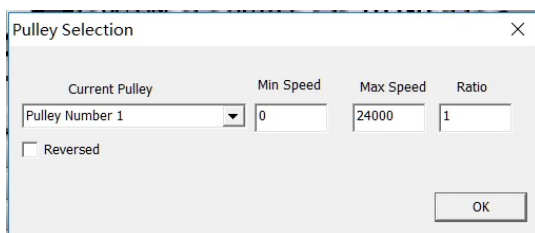

MaxSpeed--- turns per Minute.

### 3、 Moto turning and Setup:

$$\text{Mach3 steps per MM} = \text{Mach3 steps per rev} \times \text{Motor revs per MM}$$

e.g. If it moves 5MM per rev, The motor is 1.8 degree per step, and the stepper motor driver is set to 8 microstep, Then bellow is the refrence setting.

$$320 = 200 \times 8/5$$

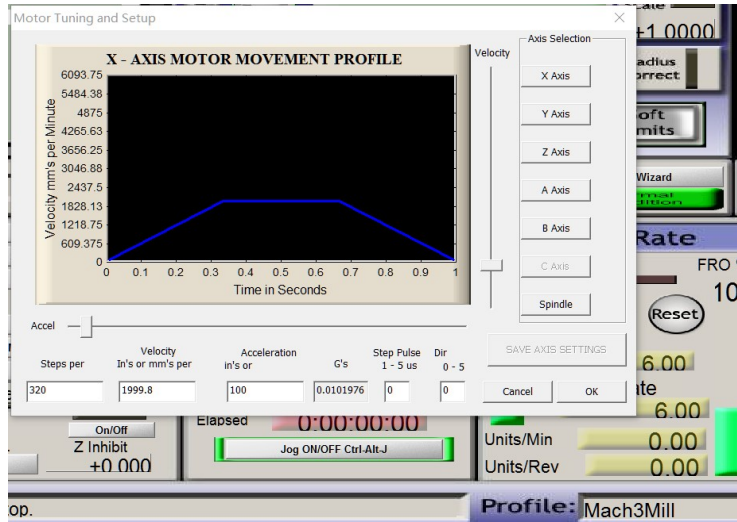

“Steps per” means steps per MM.

The setting for the other asix is the same. Don't forget to click the save button each time!

### 4、 System Hotkeys Setup:

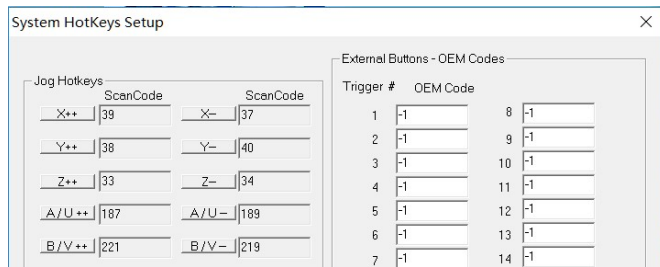

Setting the hotkey like above, Then you can use the hotkey on the keyboard to control the motor.



5、 Tool probe:

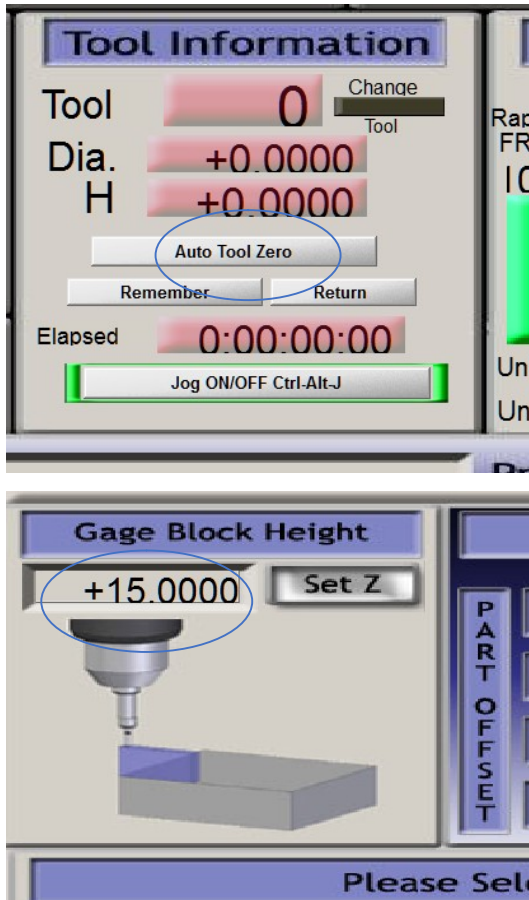

And you should set the 'Gage Block Height' on the 'Offsets Alt5' screen. When you Click the button 'Auto Tool Zero', then it will probe.

For more instructions, please refer to the MACH3 manual.

6、 MPG HandWheel connector:

MPG HandWheel Connector Terminal

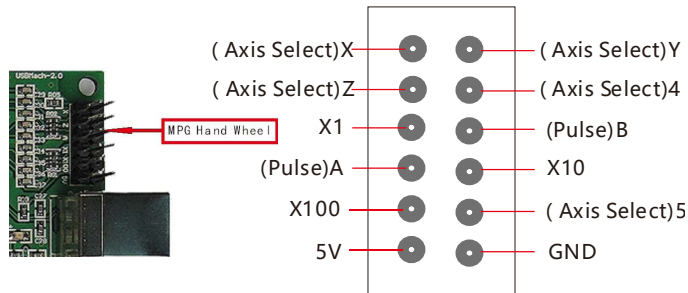

Note: The voltage for the handwheel is 5V.

Mach3 USB interface board BL-UsbMACH-V2.1 manual

Here is the common hand wheel wiring sheet:

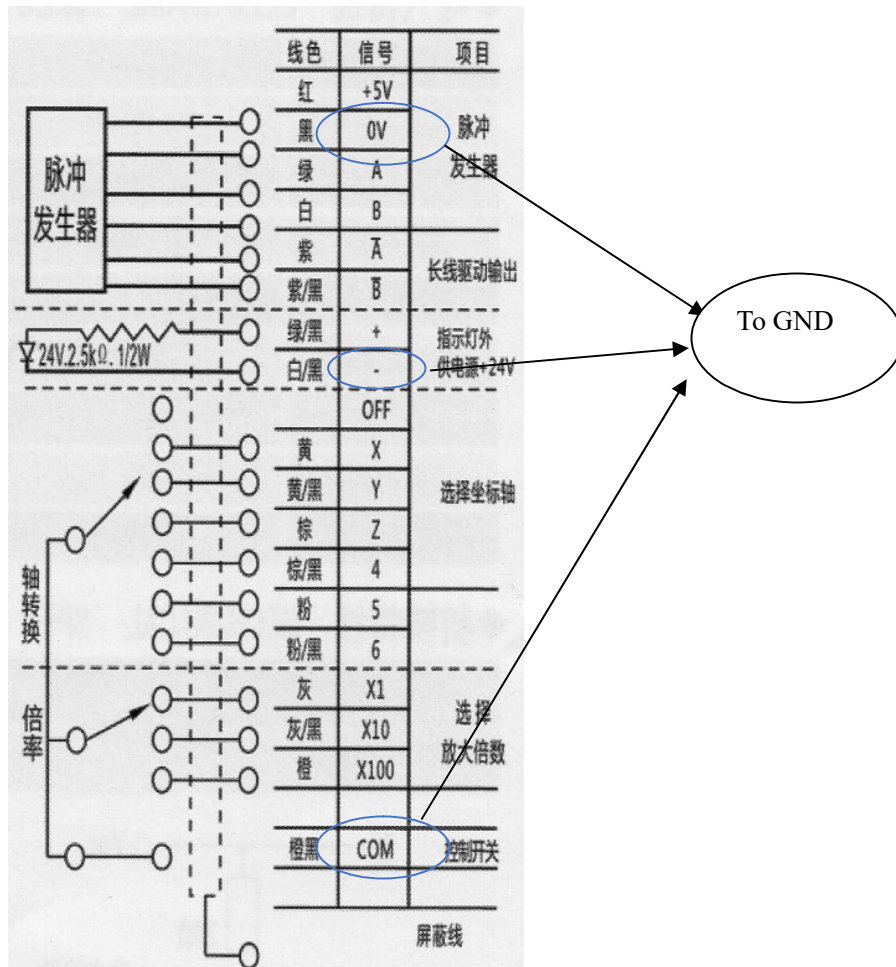

Please just pay attention to this:

The 0V(for the pulse)、COM、‘-’(for the light) all join together, and connect to GND on the handwheel connector of the UsbMach interface board.

And join the +5V、‘+’ together, and connect to 5V on the handwheel connector of the UsbMach interface board.

And connect all the other terminal just according the name of the terminal pin.

**Settings on MACH3 for the handwheel:**

**All you need to do is just a check on the figure bellow:**

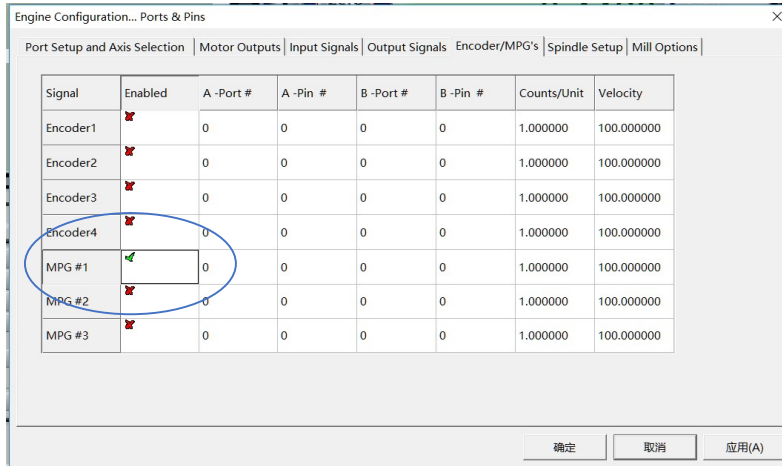

Till now, If you turn the handwheel, the coordinate on the Mach3 software should change.

**7、Expand Inputs**

**You can also use the handwheel connector as inputs. So we have 9 more new Inputs: IN6-IN14.**

**Note:** Since this 9 inputs are not separated by photocouplers, so the rule for the usage is: 1、 just can connect to switches. 2、 can not input voltage or connect to other common ground. 3、 The wire can't be too long. 4、 so, dont use them as Limit、 Home、 Probe as possible.

The figure bellow is the cross-references when use the handwheel connector as inputs:

MPG Inputs cross-references

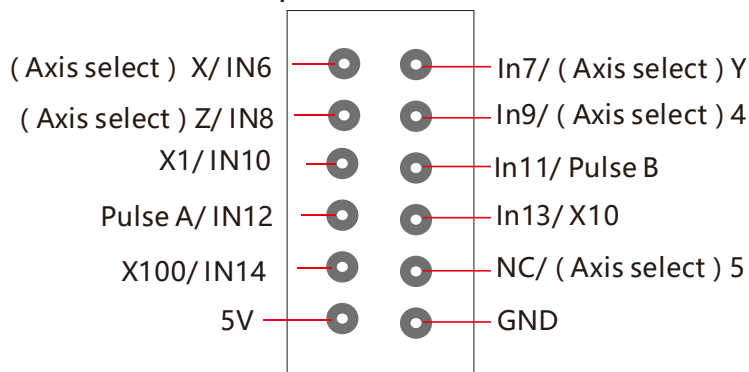

Here is the wiring diagram:

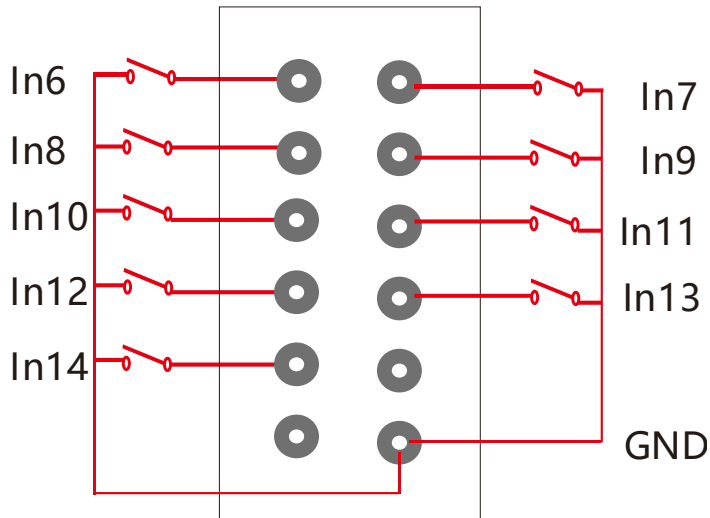

The usage for IN6-IN14 is similar to IN1-IN5.

**The Settings on MACH3 for the IN6-IN14:**

As we say above, 10、11、12、13、15 respectively represent In1、In2、In3、In4、In5 on the interface board。 And here IN6-IN14 are respectively represented by 16-24.

Setting Like the diagram bellow:

Engine Configuration... Ports & Pins

Port Setup and Axis Selection | Motor Outputs | Input Signals | Output Signals | Encoder/MPG's | Spindle Setup | Mill Options

| Signal       | Enabled                             | Port # | Pin Number | Active Low                          | Emulated                            | HotKey |
|--------------|-------------------------------------|--------|------------|-------------------------------------|-------------------------------------|--------|
| OEM Trig #1  | <input checked="" type="checkbox"/> | 1      | 16         | <input checked="" type="checkbox"/> | <input checked="" type="checkbox"/> | 0      |
| OEM Trig #2  | <input checked="" type="checkbox"/> | 1      | 17         | <input checked="" type="checkbox"/> | <input checked="" type="checkbox"/> | 0      |
| OEM Trig #3  | <input checked="" type="checkbox"/> | 1      | 18         | <input checked="" type="checkbox"/> | <input checked="" type="checkbox"/> | 0      |
| OEM Trig #4  | <input checked="" type="checkbox"/> | 1      | 19         | <input checked="" type="checkbox"/> | <input checked="" type="checkbox"/> | 0      |
| OEM Trig #5  | <input checked="" type="checkbox"/> | 1      | 20         | <input checked="" type="checkbox"/> | <input checked="" type="checkbox"/> | 0      |
| OEM Trig #6  | <input checked="" type="checkbox"/> | 1      | 21         | <input checked="" type="checkbox"/> | <input checked="" type="checkbox"/> | 0      |
| OEM Trig #7  | <input checked="" type="checkbox"/> | 1      | 22         | <input checked="" type="checkbox"/> | <input checked="" type="checkbox"/> | 0      |
| OEM Trig #8  | <input checked="" type="checkbox"/> | 1      | 23         | <input checked="" type="checkbox"/> | <input checked="" type="checkbox"/> | 0      |
| OEM Trig #9  | <input checked="" type="checkbox"/> | 1      | 24         | <input checked="" type="checkbox"/> | <input checked="" type="checkbox"/> | 0      |
| OEM Trig #10 | <input checked="" type="checkbox"/> | 0      | 0          | <input checked="" type="checkbox"/> | <input checked="" type="checkbox"/> | 0      |

Pins 10-13 and 15 are inputs. Only these 5 pin numbers may be used on this

Automated Setup of Inputs

确定 取消 应用(A)

**Quickly know the BL-UsbMach interface Board And the Software:**

1、 When you run the Mach3 software, at the beginning,  this button will flash, you need to click it to make it stop flash, then you can run the software further.

2、 If the UsbMach Board isn't connected to the PC, then  will flash all the time. You can't stop it by click the button. And the software won't work too.

3、 If the UsbMach Board is connected, the status box will show this: .  
For many conditions there is message shown on this box.

4、  On this coordinates shown box, if the coordinate of an axis change, then the same axis on the interface Board will output pulse. If there is no any coordinate change, then the interface Board won't output any pulse.

5、 if the MPG hand wheel works well, then turn the wheel, the coordinate On the coordinates shown box should change too.

6、  On this box, All the G code or M code can be inputed.

M code and the Outputs: M3—OUT1、 M4—OUT2、 M8—OUT3、 M7—OUT4。 Also you can change them too.

If you input M3 S8000, then 0-10V and PWM will work. M5 will shut off M3\M4, and the 0-10V and PWM will be shut off too.

And M9 will shut off M7\M8.

7、 If you don't input 12-24V to the board, then IN1-IN5 、 0-10V and PWM won't work. But the other function still work.